



TYPE AA ROTO-GATE

PEREY TURNSTILES

308 Bishop Ave., Bridgeport, CT 06610, USA

Toll Free 877-TURNSTILE

Tel. 203-333-9400

Fax 203-333-9410

www.TURNSTILE.com

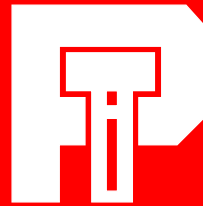

Since 1913
5 Year Warranty

GSA

Contract Holder
Contract GS-07F-5982R

TYPE AA ROTO-GATE



Designed for outdoor and indoor high security applications where attractive appearance is essential at moderate costs. Non-welded construction uniquely suited to prevent kicking arms off. Controls can be integrated into any automated security system. Automatically assures a single passage in the unlocked direction only. It is furnished powder coated to blend with the surroundings or ANSI #304 stainless finish.

The Type "AA" has...

- An Average 27 Year Service Life
- A Five Year Warranty
- Minimal Maintenance Requirements

The Type "AA" was designed for protection against even determined attacks. This strength translates into decades of normal use and abuse in all kinds of weather. The "AA" Roto-Gate can be used by both office and plant personnel. A small person can turn the Rotors more easily than a revolving door can be turned.

The Type "AA" includes non-welded construction that prevents people from breaking off arms. The "AA" employs malleable iron arm clamps that distribute throughout the rotor any force applied to the arms. Welded arms will break off at the center column because the weld alone must withstand all force.

TYPE AA ROTO-GATE

The locking mechanism of the mechanical mass-transit-type Type "AA" is an over-running clutch that is 6-1/2" by 6" by 2.5". It is manufactured of ONLY hardened steels in a flame cut steel housing. The locking elements of the mechanism in these turnstiles are two ratchets and two locking pawls each made of 1.250 inch thick hardened steel. Combined, this means 2.5 inches of hardened steel prevents penetration.

The electronically controlled Type "AA" includes our "500J", "500H" or "500FS" control mechanism. This mechanism has an MCBF of 1.2 million cycles. Part of the success of this mechanism is due to the very large and efficient solenoids we employ. Part is due to our unique unlocking/locking controls in the "500J" series mechanism which prevent the solenoids from EVER getting hot even in direct equatorial sunshine.

Even our Bottom Bearing is perfectly suited to a production environment or area where salts are present from snow melting chemicals. In an acidic or gritty environment, a bottom bearing that includes sealed ball bearings will not survive. Acids will disintegrate the seal and destroy the ball races.

Our Bottom Bearing is a 1.5 inch thick by 12 inch diameter gray iron casting. A 1.5 inch diameter drill rod steel shaft thrusts through the Bottom Bearing and centers the Rotor onto its 6" diameter bearing surface. No ball bearings are needed.

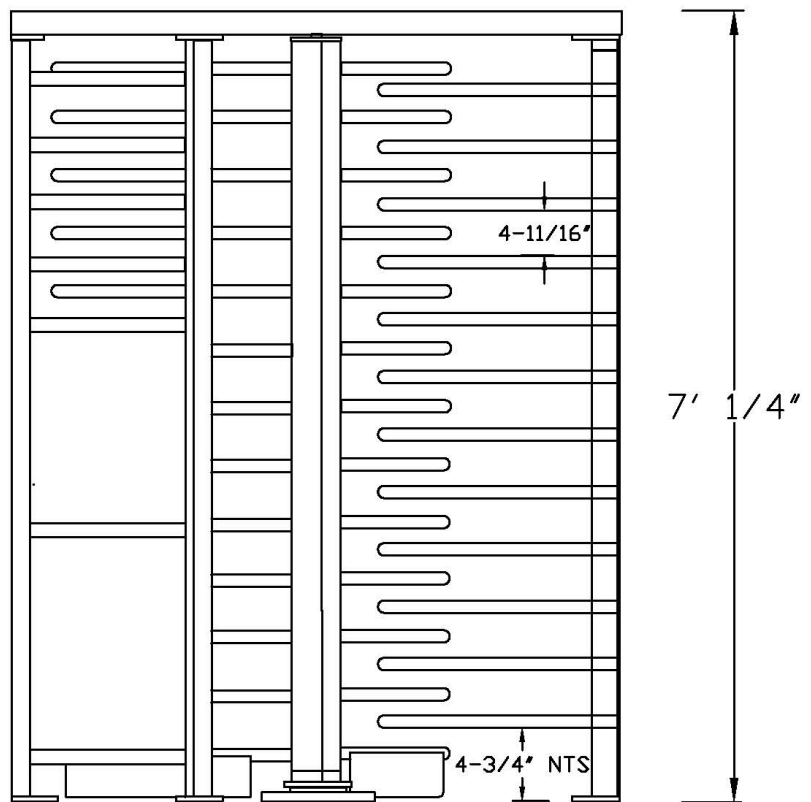
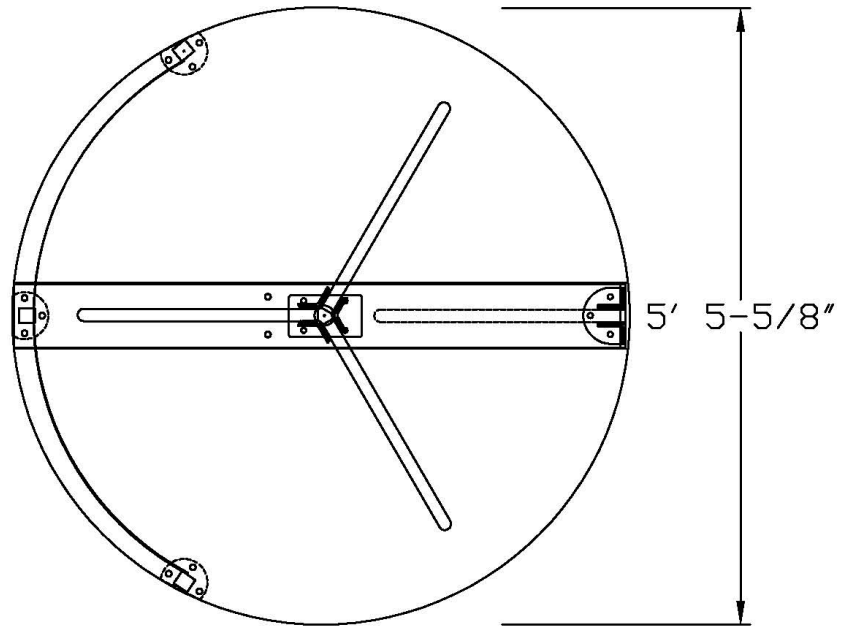

Short Form Specification

Weight: 856 lbs. Net - 920 lbs. Crated.

Arms: Square steel tubing, walls 0.097" thick, ends spun closed, bottom arms with heel guards.

Rotor and Barrier Columns: Five angles of 0.25" thick steel, sixty-three malleable cast iron clamps, non-welded construction.

Vertical Cage Members: 3 "U" channels 0.097" wall thickness, passage sheet 4' high by 5'2" length of 0.048" thick steel, 7 reinforcing bands of 0.38" thick steel.

Mechanism: All steel and machined cast iron. Two control ratchets each 1.25" thick hardened steel. Two locking pawls each 1.25" thick hardened steel.

Bottom Bearing: Machined Grey Iron Casting 1.50" thick, 12" diameter.

Ceiling: full round steel sheet 0.052" thick with 1"x1" circular reinforcing angle at edge



TYPE AA ROTO-GATE

PEREY TURNSTILES

308 Bishop Ave., Bridgeport, CT 06610, USA

Toll Free 877-TURNSTILE

Tel. 203-333-9400

Fax 203-333-9410

www.TURNSTILE.com

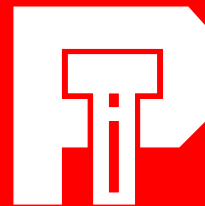

Since 1913
5 Year Warranty

GSA

Contract Holder
Contract GS-07F-5982R