



MODEL 151SF DROP ARM TURNSTILE

PEREY TURNSTILES

308 Bishop Ave., Bridgeport, CT 06610, USA

Toll Free 877-TURNSTILE

Tel. 203-333-9400

Fax 203-333-9410

www.TURNSTILE.com

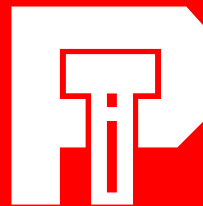

Since 1913
5 Year Warranty

GSA

Contract Holder
Contract GS-07F-5982R



MODEL 151SF DROP ARM TURNSTILE



Perey Turnstiles manufactures a unique product line for use by people who need BOTH clear passageway from 16" to 72" wide AND the security of a tripod Turnstile - the Drop Arm Turnstile. This device is designed to provide access control functions similar to that of a tripod-turnstile while allowing a free passage width adequate for wheel chairs, carts, etc.

The Drop Arm Turnstile has one or two passage barring arms that drop into recesses in the cabinet. An array of optical sensors monitor the passageway and provides optical-turnstile alarm functionality. Once the barrier has dropped out of the passageway, the unit becomes a completely functional optical turnstile.

We have been manufacturing Optical Turnstiles since the late 1950's. We have often found that since Optical Turnstiles do not have barriers, the timing of when alarms are triggered and the pattern of traffic flow has a far greater impact on Optical Turnstile use than they have on Tripod Turnstile use (when there is a barrier people tend to be sure they are allowed to pass through long before they are in the turnstile's passageway).

By adding a barrier arm, the Drop Arm Turnstile provides a compromise between the greater security of a tripod turnstile and the openness of an optical turnstile.



MODEL 151SF DROP ARM TURNSTILE

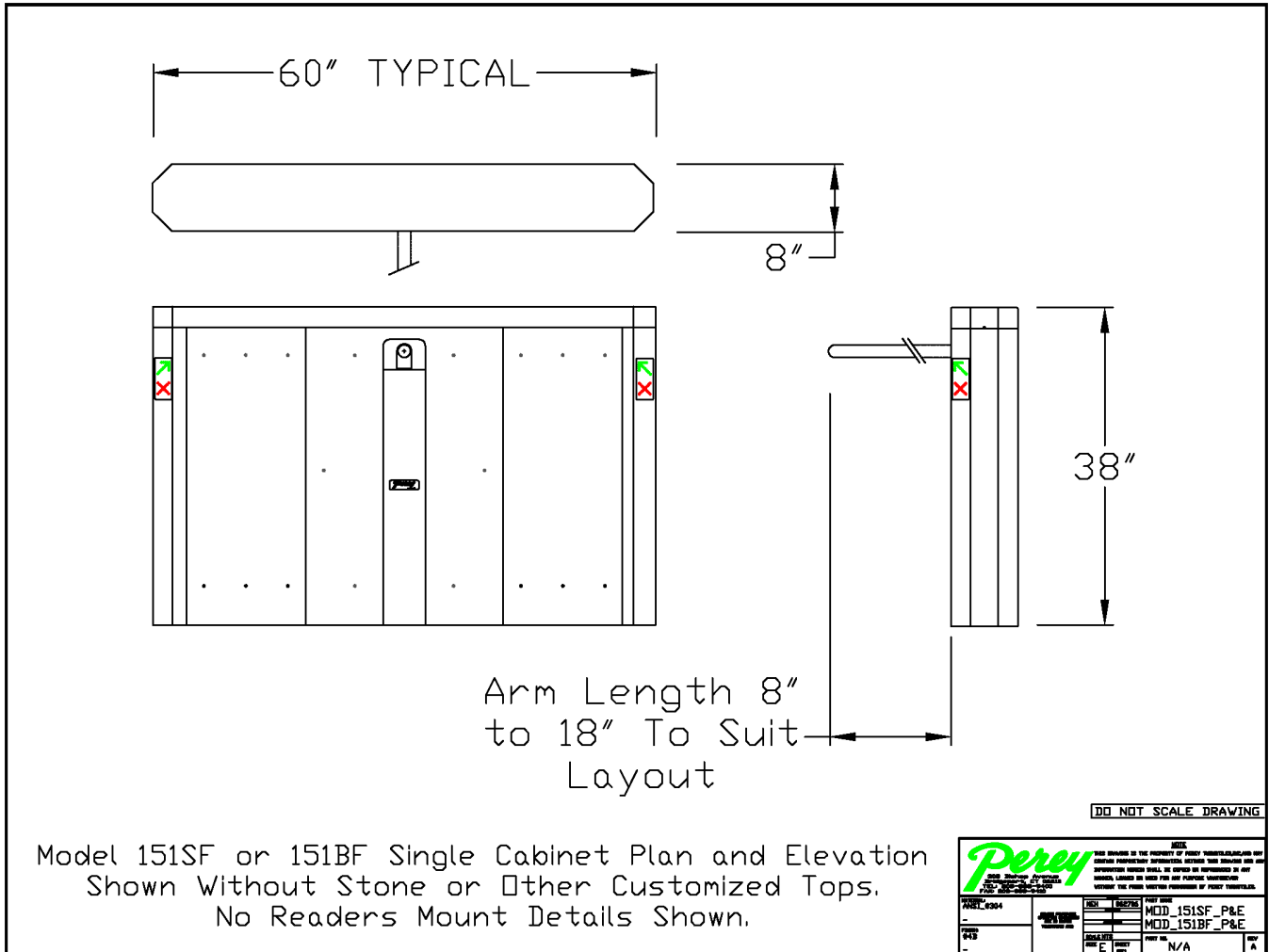

We have recently added a remote programming feature to our Optical Turnstile controller. Our new "SuperController" can be remotely programmed to meet a customer's changing requirements. This can be accomplished without the need for a factory technician's visit.

When operational requirements change, simply call us with the new requirements and we will e-mail you the new programming, upload and test the new program using a laptop computer.

The Model "151SF/xx" is designed for use in the most attractive lobbies and corporate headquarters.

The Model "151SF/xx" includes an ANSI #304 stainless steel cabinets. It has an array of industrially-hardened aperture controlled sensors that monitor the passageway. The "brain" of the Model "151SF/xx" is our new "SuperController".

The Model "151SF/xx" can be customized to fit the particular needs of an application. Custom features such as marble tops, added or reduced length and customized reader mounting is available along with customized indicator lights.

All of our Drop Arm Turnstiles are programmable to allow the following features:

- Uni-Directional Operation
- Bi-Directional Operation
- Remote "Lockout" Of One Or Both Directions
- Unauthorized Entry Alarm Local and Remote
- Unauthorized Exit Alarm Local and Remote
- Piggy Backing Alarm Local and Remote
- Package Only Entry Alarm Local and Remote
- Package Only Exit Alarm Local and Remote
- Slow Travel Alarm Local and Remote
- Walk Away Alarm Local and Remote
- Crawl Alarm Local and Remote



MODEL 151SF DROP ARM TURNSTILE

PEREY TURNSTILES

308 Bishop Ave., Bridgeport, CT 06610, USA

Toll Free 877-TURNSTILE

Tel. 203-333-9400

Fax 203-333-9410

www.TURNSTILE.com

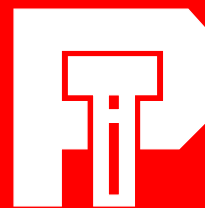

Since 1913
5 Year Warranty

GSA

Contract Holder
Contract GS-07F-5982R