



# MODEL 136BS TRIPOD TURNSTILE

## PEREY TURNSTILES

245 WESTCHESTER AVE, UNIT 866 PORT  
CHESTER, New York 10573, USA

Tel. 203-333-9400

[www.TURNSTILE.com](http://www.TURNSTILE.com)

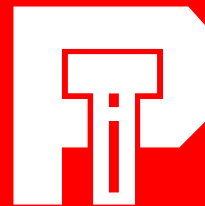

Since 1913  
5 Year Warranty

Through the Generations,  
People Turn to Perey.



## MODEL 136BS TRIPOD TURNSTILE

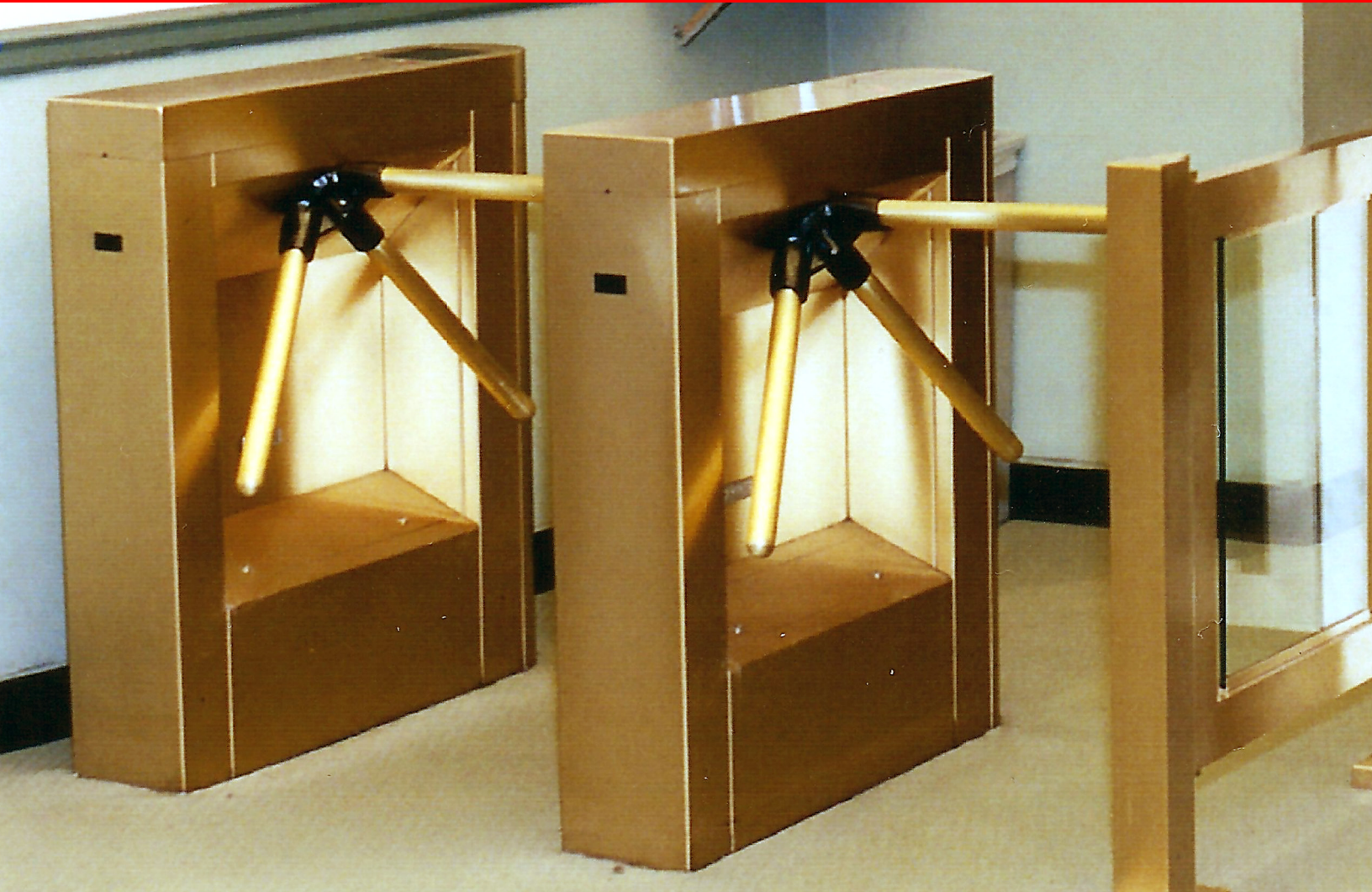

Designed for beautiful lobbies where a brass finish is required and space limited or large electronics must be mounted on the front face of the turnstile such as biometric scanners with built-in card readers. Selected by companies that require the security ONLY a tripod-turnstile can provide. Our unique finish never tarnishes and never needs re-polishing. Even significant scratched can hardly be seen and is easily repaired. Cabinet designed for internal mounting of proximity magnetic stripe and other card reader technologies. Electronics packages and power supplies serving the card readers can be mounted inside the electronics enclosure. Photoelectric sensors can be provided on both inbound and outbound sides to increase security protection. Lighted enunciators reading PRESENT CARD/PLEASE PROCEED. Other messages, are available.



# MODEL 136BS TRIPOD TURNSTILE

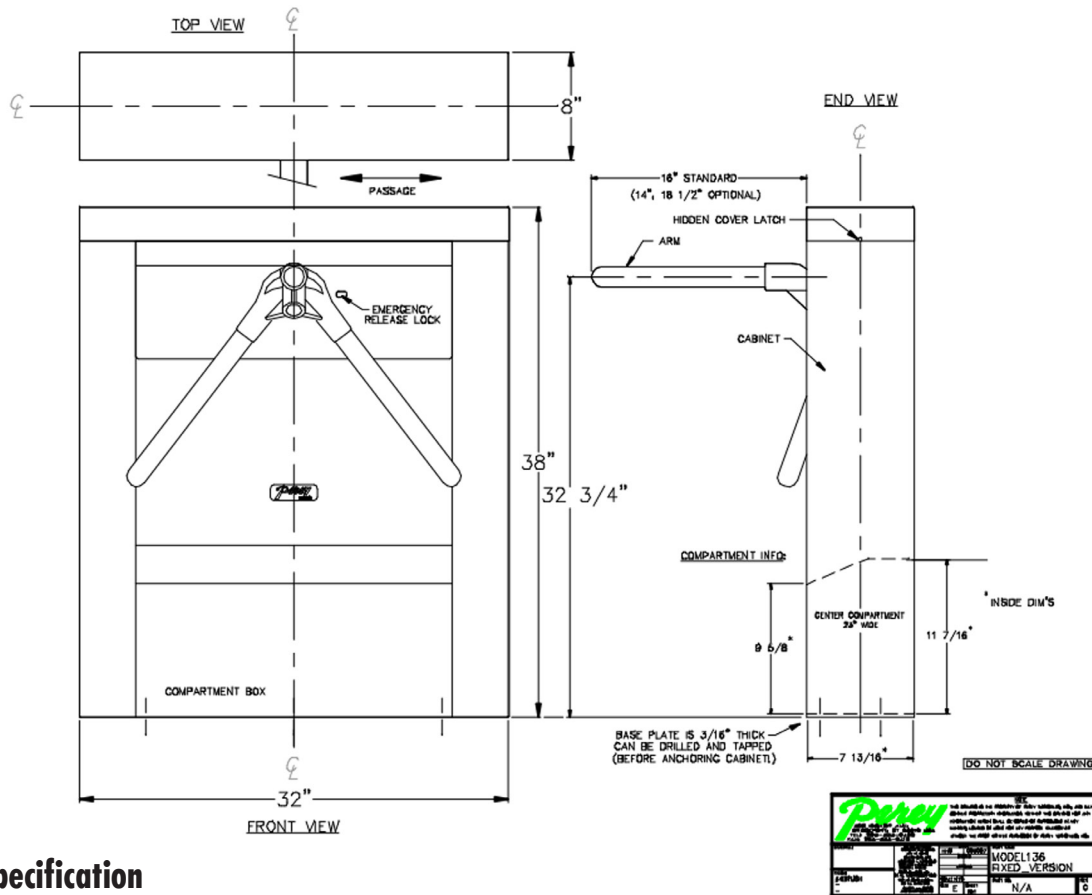

## Short Form Specification

**WEIGHT:** 175 lbs. Net - 215 lbs. crated.

**COVER:** ANSI 304 Stainless steel with #4 brushed finish coated with marine-grade powder coat incorporating brass coloring, .078" thick, 0.25" radii corners, sides 2.5" deep, fully radius'd ends.

**CABINET:** ANSI 304 stainless steel with a #4 brushed finish coated with marine-grade powder coat incorporating brass coloring. Each wall .078" thick. Electronics housing between turnstile legs with housing access door having two locks. 32" long by 38" tall by 8" wide. Up to 22" passageway width.

**ARMS:** ANSI 304 Stainless steel tubing brushed finish, spun closed ends.

**HUB:** Solid steel with solid steel taper pin mounting.

**MECHANICAL MECHANISM:** Ratchet of 1" x 6.5" machined cast iron. Use aided by springs of 0.175" dia. spring steel. Motion stabilized by large rotary shock absorber and 1" thick cast iron two-lobe cam. Self Centered by 3/4" laminated steel compression shoe.

**Unlocking Controls:** One continuous-duty rated 24VDC solenoid with 620% of required strength. Solenoid operates for 45 milliseconds per passage. All unlocking elements are mechanical. No time relays or transformers.



# MODEL 136BS TRIPOD TURNSTILE

## PEREY TURNSTILES

245 WESTCHESTER AVE, UNIT 866 PORT  
CHESTER, New York 10573, USA

Tel. 203-333-9400

[www.TURNSTILE.com](http://www.TURNSTILE.com)

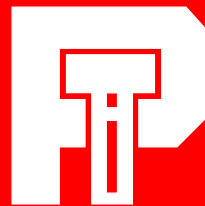

Since 1913  
5 Year Warranty

Through the Generations,  
People Turn to Perey.